

RIVERA II

Rivera Hammered Bar/Prep Sink
NS25033



THOMPSON

FEATURES

- Rectangular hand hammered design
- Easy to clean and maintain
- Rigorously tested to ensure no puddling or leaking
- Coordinating drain available
- Limited Lifetime Warranty

DIMENSIONS & WEIGHT

- Outer 21.5" x 19.5", 10" depth
- Inner 18" x 16", 10" depth
- Drain 3.5"
- Weight 7.8-9.4 pounds depending on model number

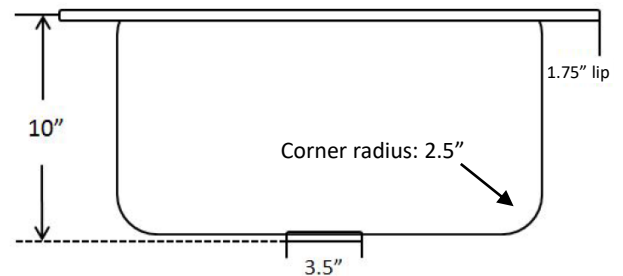
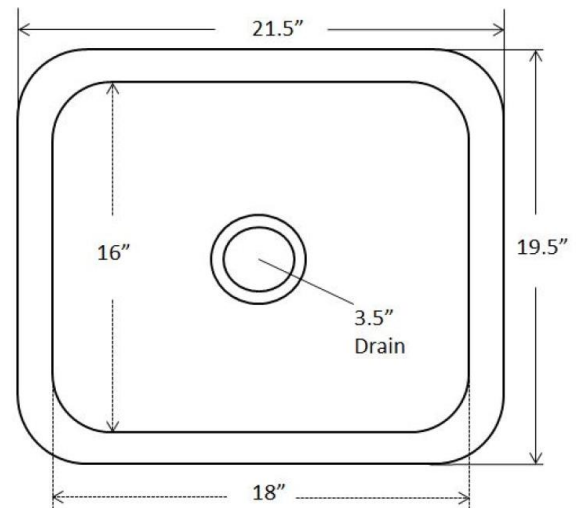

AVAILABLE MATERIALS/FINISHES

Images intended for reference only:

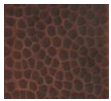

Rivera Antique Copper
Item Code: NS25033H
Drain: TDD35-AC or TDB35-AC

***Due to the hand-made nature of our sinks, all dimensions may vary +/- .25" in any direction. We do not provide templates and recommend that all countertops or projects be templated from the sink itself.*



Contact us at customerservice@thompsontraders.com or (336) 272-3003.
Thompson reserves the right to make revisions without notice to product specifications.
For the most current Specification Sheet, go to www.thompsontraders.com